

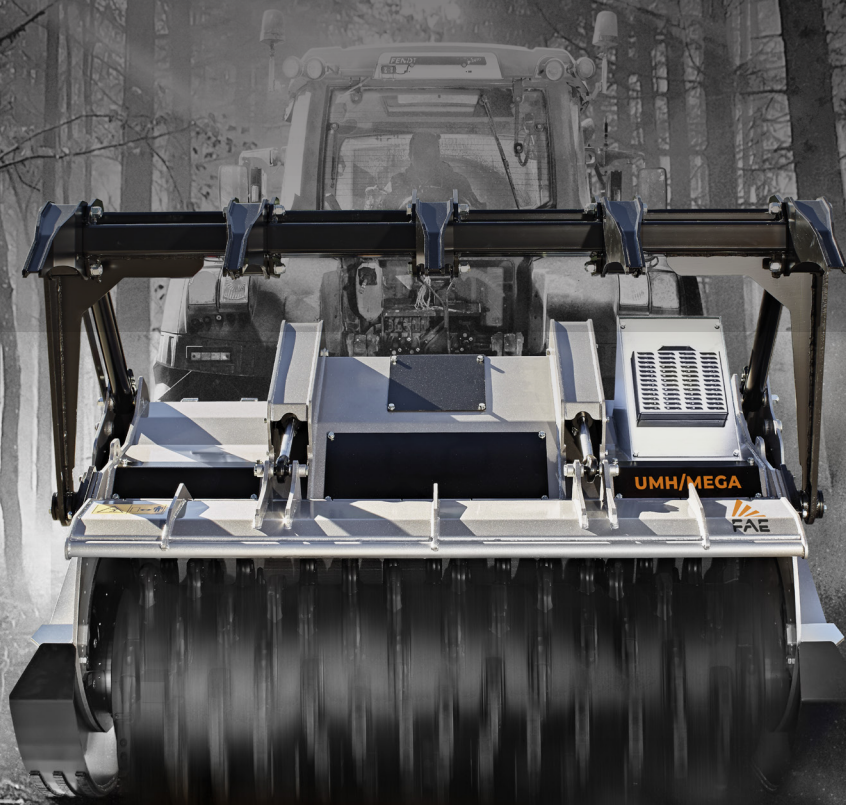

LAND CLEARING PTO Driven Heads



6 ABOUT FAE

8 MAKE THE DIFFERENCE

**10 RIGHT TO THE
HEART OF POWER**

**12 LAND CLEARING
PTO DRIVEN HEADS**

14 FORESTRY MULCHERS

- 18 PATRIZIO
- 20 UML/ST - FML/ST
- 22 UML/LOW
- 24 UML/DT - FML/DT
- 26 UML/S/DT
- 28 UMM/DT
- 30 UMM/S - UMM/S/HP
- 32 UMH/S - UMH/S/HP
- 34 UMH/MEGA

36 FORESTRY TILLERS

- 40 SSL SPEED
- 42 SSL
- 44 SSM - SSM/HP
- 46 SSH - SSH/HP

48 STUMP CUTTERS

- 52 SCH
- 54 SCH/GT

56 STONE CRUSHERS

- 60 STCL
- 62 STC
- 64 STCH
- 66 RSL
- 68 RSM - RSM/HP
- 70 RSH/HP

72 MULTITASKS

- 76 SFM
- 78 SFH - SFH/HP

82 ORIGINAL FAE TOOLS



MAKE THE **DIFFERENCE**

At FAE, every machine, accessory and optional component is designed with utmost precision, the highest quality materials and the most advanced technology.

Each detail is designed to make the execution of the tasks as quick and efficient as possible and for the specific applications, conditions and environment where it will be carried out.

Every FAE machine and accessory was created to make a difference at work and, given the importance of many of the applications we work on, for the planet. This is why each member of our team, each partner and customer works daily.



ABOUT **FAE**

With a range of over 90 products and 400 models, FAE can meet the most diverse demands for forestry, agricultural, road construction, building and demining applications. The FAE product range includes heads for tractors, excavators, skid steer loaders, special vehicles and tracked vehicles, with cabins or remote controlled. FAE was founded in 1989, and the company's main office is still located in Fondo, Italy. Production, sales, after-sales service and parts services are handled by our 4 production sites, the main office, 6 commercial branches and a network of authorized dealers all over the world.

GLOBAL QUALITY

Our precision design and production processes use advanced technologies to ensure long-term performance and reliability.

CONSTANT INNOVATION

We design unique and cutting-edge products based on customers' specific needs for solutions that pave the way to the future.

COMPLETE PRODUCT LINE

We offer an extensive product range and a high degree of customization to make each process more efficient more productive and easier.

TOTAL SUPPORT

We make our vast range of machines, dedicated accessories and components, as well as our technical assistance available worldwide.

MAKE THE DIFFERENCE

Our machines are designed with special attention to detail. Starting from the technical design to our choice of high quality materials, our machines are highly resistant to wear and tear. The FAE brand is always recognized for its high quality standards.

1

2

3

4

5

6

7

8

1 / Recessed bolts to protect from wear

2 / Conical hitch for 3-point linkage arms

3 / Access points to facilitate the maintenance

4 / Side Protection

5 / Hose Protection

6 / Forged and hardened stub axles bolted on the rotors

7 / Adjustable Hardox® counter-blade

8 / Inner anti wear clad plate FCP



Internal interchangeable counter-blade.

RIGHT TO THE HEART OF THE POWER

The spiral rotor design reduces the power requirement

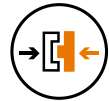

EASIER ON THE TRACTOR ENGINE



FINER, MORE CONSISTENT FINAL PRODUCT



LESS FUEL CONSUMPTION



HIGHER PRODUCTIVITY

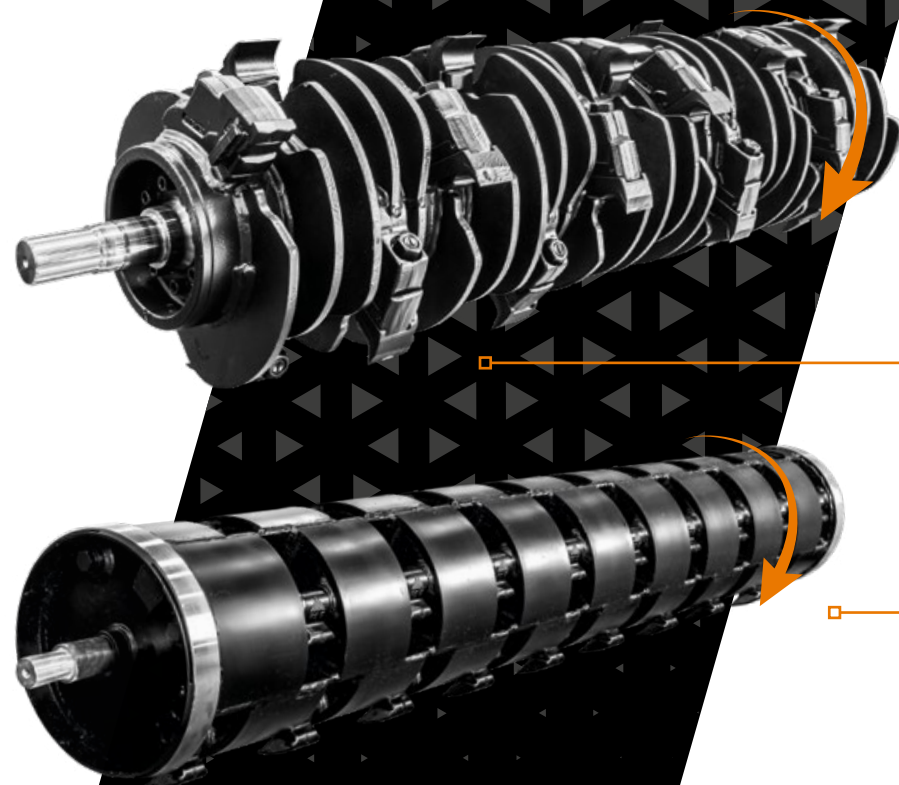

Forestry rotor with double carbide teeth

Ideal for heavy duty forestry applications (above ground mulching). Resistant to impact and wear. This rotor can be fitted with different tool types: TOOTH C/3, TOOTH C/3/HD, TOOTH STCL/3, TOOTH I, TOOTH K, BLADE BL.



Forestry rotor with single carbide teeth

Ideal for grinding stumps above and below ground. This rotor can be fitted with different tool types: TOOTH A/3, TOOTH A/3/HD, TOOTH B/3, TOOTH B/3/HD, TOOTH F/3, TOOTH G/3.



Rock crusher rotor

To achieve perfect sizing of the final product in agriculture land reclamation. This rotor can be fitted with different tool types: TOOTH STC/3, TOOTH STC/3/HD, TOOTH STC/3/FP.



Bite Limiter

Special steel limiter rings control the depth of blade action.

Swinging hammer rotor

Ideal for applications with high presence of rocks. This rotor can be fitted with HAMMER FMM.

LAND CLEARING **PTO DRIVEN HEADS**

Our mechanical PTO heads stand up to any shredding and mulching task with exceptional results. Designed for the intended use and the power of the vehicle they are mounted on, all of our forestry mulchers and tillers, stone crushers, stump cutters and multi-purpose heads provide unparalleled performance in every situation.



FORESTRY MULCHERS

Our forestry mulchers combine quality and efficiency with the longest lasting components. Applications include shredding trees, bushes, leftover trimmings, crop debris, and underbrush. Our mulchers allow you to work in narrow spaces or where maneuvering is limited, thanks to their compact design.



PaTriziO
FAE's small mulcher with Bite Limiter technology for tractors.



UML/ST - FML/ST
Mulchers with fixed teeth / swinging hammer rotors for tractors.



UML/LOW
Fixed-tooth mulcher for low profile tractors.



UML/DT - FML/DT
Forestry mulcher with fixed tooth rotor (UML/DT) or swinging hammer rotor (FML/DT).



UML/S/DT
Forestry mulcher for PTO tractors with fixed tooth rotor.



UMM/DT
Forestry mulcher for PTO tractors with fixed tooth rotor.



UMM/S - UMM/S/HP
Forestry mulchers for PTO tractors with fixed tooth rotor.



UMH/S - UMH/S/HP
Forestry mulchers for PTO tractors with fixed tooth rotor.

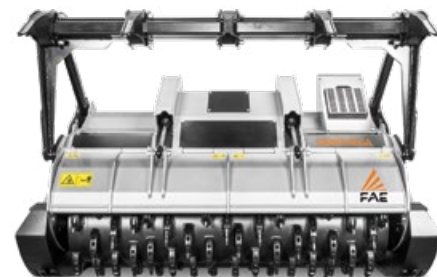

UMH/MEGA
Forestry mulcher for PTO tractors with fixed tooth rotor.



THE SOLUTION TO ALL YOUR NEEDS.

MODEL	0 - 100 hp	100 - 200 hp	200 - 300 hp	300 - 400 hp	400 - 500 hp
PaTrizi®	50 - 100 hp				
UML/ST - FML/ST	50 - 110 hp				
UML/LOW	60 - 110 hp				
UML/DT - FML/DT	80 - 130 hp				
UML/S/DT		130 - 190 hp			
UMM/DT		160 - 240 hp			
UMM/S - UMM/S/HP			180 - 350 hp		
UMH/S - UMH/S/HP			240 - 500 hp		
UMH/MEGA				350 - 500 hp	

FORESTRY MULCHERS

PaTrizio

FAE's small mulcher with Bite Limiter technology for tractors.

PaTrizio mulcher works on trees branches and bushes up to 15 cm in diameter and is great for mulching pruning debris. The rotor features Bite Limiter technology. Steel limiter rings limit the depth of cut, reducing power demand and guaranteeing exceptional performance.

PaTrizio has adjustable and interchangeable bolted skids, two rows of counter blades for fine, even mulching, a hydraulic hood with built-in cylinder protected by the machine body, and a heat-treated forged-steel tooth holder with BL/MINI blades and C/3/MINI teeth.



50-100 hp



Ø 15 cm max



Two rows of counter blades for finer mulching



Bite Limiter rotor special steel profiles limit the depth of cut



Hydraulic hood for optimal mulching, reduces the ejection of mulched material

Two rows of screwed chains limits mulched material output



Adjustable skids for adjusting the rotor's penetration of the ground

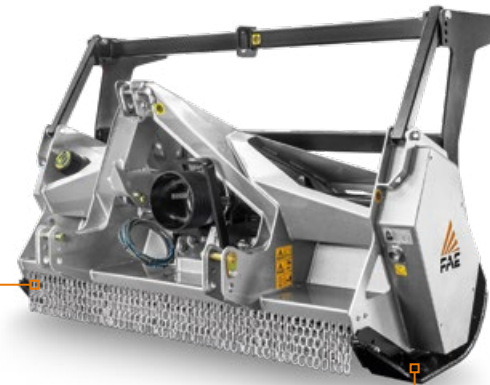

STANDARD EQUIPMENT

Hydraulic rear hood	PTO shaft with cam clutch
Enclosed machine body	Bolted-on rotor shafts (in forged steel)
Cylinder protection	Bite Limiter Rotor
Protection chains	Welded steel counter-blades
Transmission with belts	Adjustable skids
Gearbox with freewheel	

OPTIONS

Frontal attachment	Hydraulic top link
Multiple tooth options	Mechanical guard frame
Possibility to choose transmission 540 / 1000 rpm	

MODEL	PATRIZIO 150	PATRIZIO 175	PATRIZIO 200
Tractor (hp)	50-100	50-100	50-100
PTO (rpm)	540-1000	540-1000	540-1000
Working width (mm)	1480	1720	1960
Total width (mm)	1746	1986	2226
Weight (kg)	780	880	980
Rotor diameter (mm)	370	370	370
Max shredding diameter (mm)	150	150	150
No. blades type BL/MINI	28	32	36

Data refers to machine as standard. The technical data in this catalogue may be altered without prior notice.

MAIN OPTIONS



Mechanical guard frame guides the material before mulching

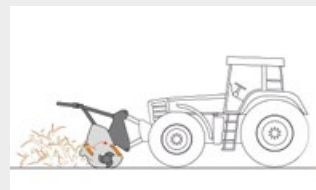

Frontal attachment



BLADE BL/MINI (standard)



TOOTH C/3/MINI (option)

FORESTRY MULCHERS

UML/ST - FML/ST

Mulchers with fixed teeth / swinging hammer rotors for tractors.

The UML/ST and the FML/ST are mulchers designed and built to be used with tractors or low-power mechanical PTO vehicles (50 to 110 hp) for all shredding work involving bushes, branches, and trees with max. diameter of 20 cm. Their compact size, superior performance, and sturdiness make them ideal in every situation.

The UML/ST has a fixed-tooth rotor that makes it possible to choose between blades, Tungsten Carbide cutting tools or durable teeth suitable for rocky soil. The FML/ST is built with a swinging hammer rotor.



50-110 hp



Ø 20 cm max

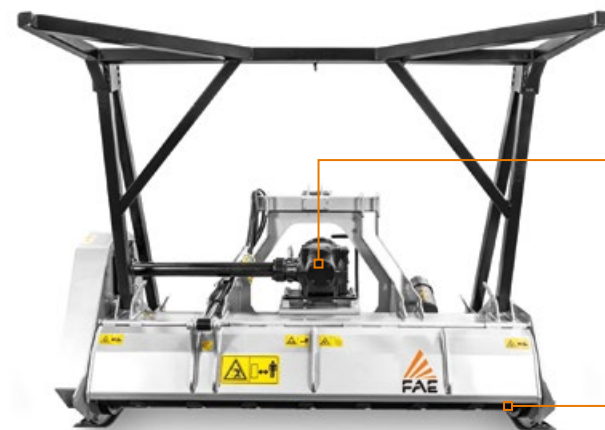

Mechanical push frame
(optional)



Reversible gear box for frontal attachment
(optional)

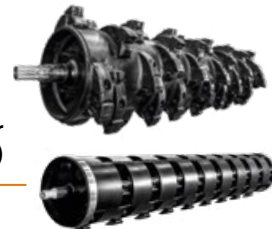

Rotor with fixed (UML/ST) or swinging hammers (FML/ST)



STANDARD EQUIPMENT

Hydraulic rear hood	PTO shaft (FML/ST)
Dual row protection chains	PTO shaft with cam clutch (UML/ST)
Transmission with belts	Bolted-on rotor shafts (in forged steel) (UML/ST)
Gearbox with freewheel	Welded steel counter-blades
Possibility to choose Transmission 540 / 1000 rpm	Adjustable skids

OPTIONS

Frontal attachment	Hydraulic top link
Extended 3 point linkage	Special skids to go underground (UML/ST)
Multiple tooth options (UML/ST)	Mechanical guard frame

MODEL	UML/ST 125	UML/ST 150	UML/ST 175	UML/ST 200	FML/ST 125	FML/ST 150	FML/ST 175	FML/ST 200
Tractor (hp)	50-100	60-110	70-110	80-110	50-100	60-110	70-110	80-110
PTO (rpm)	540 - 1000	540 - 1000	540 - 1000	540 - 1000	540 - 1000	540 - 1000	540 - 1000	540 - 1000
Working width (mm)	1342	1582	1822	2062	1340	1580	1820	2060
Total width (mm)	1637	1877	2117	2357	1637	1877	2117	2357
Weight (kg)	840	930	1060	1190	820	890	950	1020
Rotor diameter (mm)	425	425	425	425	425	425	425	425
Max shredding diameter (mm)	200	200	200	200	200	200	200	200
No. teeth type C/3+C/3/SS	26+2	32+2	36+2	42+2	-	-	-	-
type I+C/3/SS	36+2	42+2	50+2	58+2	-	-	-	-
No. hammers type FMM	-	-	-	-	20	24	28	32

Data refers to machine as standard. The technical data in this catalogue may be altered without prior notice.

MAIN OPTIONS

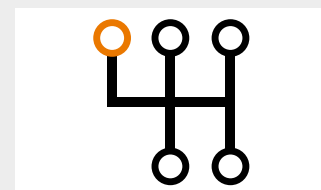

Possibility to choose transmission 540 rpm and 1000 rpm

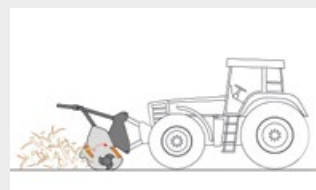

Frontal attachment



Mechanical push frame
guides and pushes material away from carrier

ROTOR TYPE C



TOOTH C/3
(standard)



TOOTH C/3/HD
(option)



BLADE BL
(option - requires adaptor)



TOOTH K/3
(option)

ROTOR TYPE I



TOOTH I
(option)



TOOTH C/3/SS
(side scraper)



HAMMER FMM
(standard)

FORESTRY MULCHERS

UML/LOW

Fixed-tooth mulcher for low profile tractors.

Its compact size and design features make the UML/LOW forestry mulcher perfect for tracked or wheeled tractors, even in orchards or vineyards. It works with 60-110 hp tractors and shreds bushes, branches and trees up to 20 cm in diameter.

The low PTO helps the main universal joint work at the best angle, and its frame has been reinforced to withstand the axial loads caused when steering the carrier. Choose between blades or durable teeth suitable for rocky soil.



60-110 hp



Ø 20 cm max

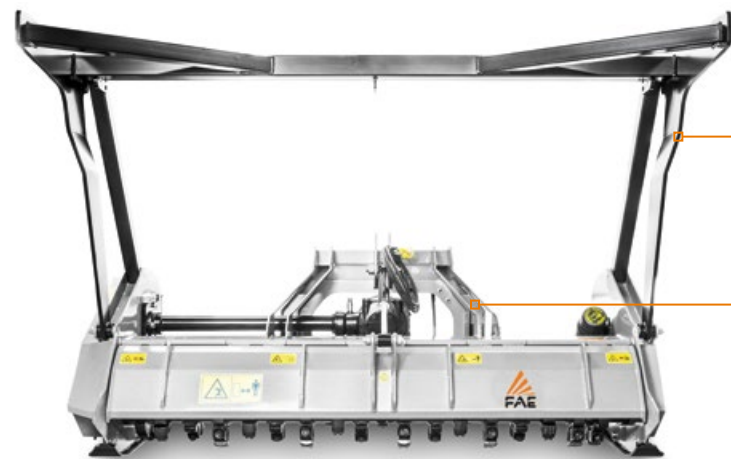

Mechanical push frame
(optional)

Heavy duty reinforced frame

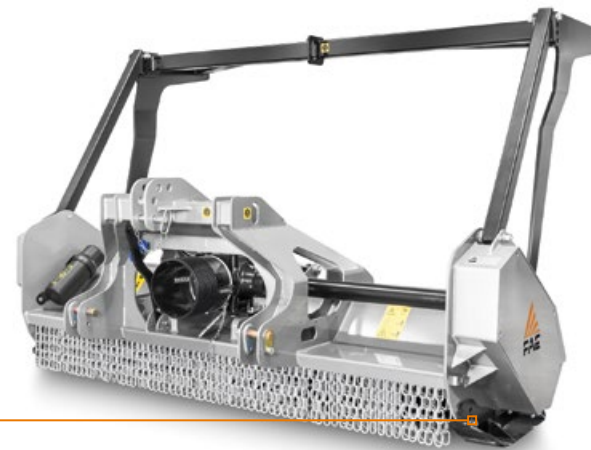

Adjustable skids

STANDARD EQUIPMENT

Hydraulic rear hood	PTO shaft with cam clutch
Dual row protection chains	Bolted-on rotor shafts (in forged steel)
Transmission with belts	Welded steel counter-blades
Gearbox with freewheel	Adjustable skids
Possibility to choose Transmission 540 / 1000 rpm	

OPTIONS

Multiple tooth options	Special skids to go underground
Hydraulic top link	Mechanical guard frame

MODEL	UML/LOW 150	UML/LOW 175	UML/LOW 200
Tractor (hp)	60-100	70-110	80-110
PTO (rpm)	540-1000	540-1000	540-1000
Working width (mm)	1582	1822	2062
Total width (mm)	1877	2117	2357
Weight (kg)	930	1060	1190
Rotor diameter (mm)	425	425	425
Max shredding diameter (mm)	200	200	200
No. teeth type C/3+C/3/SS	32+2	36+2	42+2
type I+C/3/SS	42+2	50+2	58+2

Data refers to machine as standard. The technical data in this catalogue may be altered without prior notice.

MAIN OPTIONS

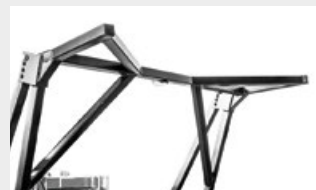

Mechanical push frame
guides and pushes material
away from carrier



**Special skids to go
underground**



Mulcher designed for tractors with a low profile PTO

ROTOR TYPE C



TOOTH C/3
(standard)



TOOTH C/3/HD
(option)



BLADE BL
(option - requires
adaptor)



TOOTH K/3
(option)

ROTOR TYPE I



TOOTH I
(option)



TOOTH C/3/SS
(side scraper)

FORESTRY MULCHERS

UML/DT - FML/DT

Forestry mulcher with fixed tooth rotor (UML/DT) or swinging hammer rotor (FML/DT).

A high production forestry mulcher with the strength to mulch bushes, crop residue, and trees up to a maximum 25 cm in diameter. The UML/DT - FML/DT has a compact size and heavy duty construction making it an ideal solution for many different applications.

The dual transmission allows for better power distribution, giving the mulcher better mechanical advantage when working in heavy material.



80-130 hp



Ø 25 cm max

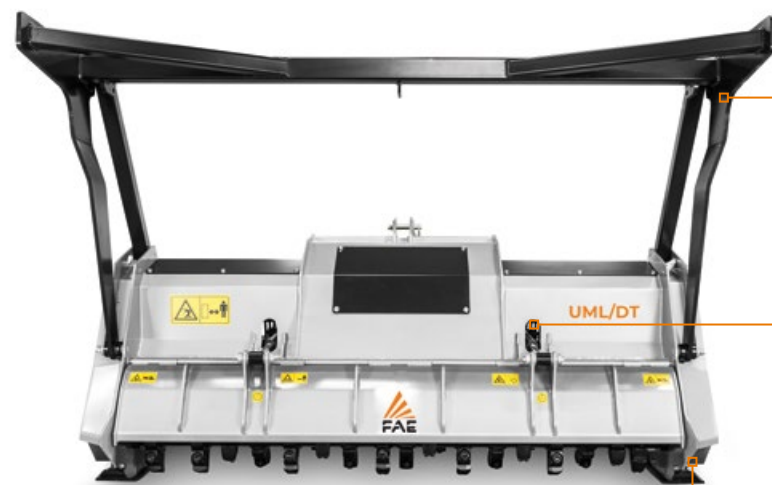

Mechanical guard frame (optional)

Hydraulically controlled rear door with two cylinders for better reliability



Heavy duty skids

Transmission with belts in XPB



Adjustable skids

STANDARD EQUIPMENT

Hydraulic rear hood	Gearbox with freewheel
Enclosed machine body	PTO shaft with cam clutch (UML/DT)
Centralized greasing hub	PTO shaft (FML/DT)
Hydraulic hoses integrated in the frame	Bolted-on rotor shafts (in forged steel) (UML/DT)
Cylinder protection	Welded steel counter-blades
Dual row protection chains	Adjustable skids
Transmission with belts	

OPTIONS

Frontal attachment	Hydraulic top link
Extended 3 point linkage	Special skids to go underground (UML/ST)
Bolt-on chain's protection plates (UML/ST)	Mechanical guard frame
Multiple tooth options (UML/ST)	Hydraulic guard frame

MODEL	UML/DT 200	UML/DT 225	FML/DT 200	FML/DT 225
Tractor (hp)	80-130	90-130	80-130	90-130
PTO (rpm)	1000	1000	1000	1000
Working width (mm)	2062	2334	2062	2334
Total width (mm)	2342	2582	2342	2582
Weight (kg)	1500	1600	1350	1460
Rotor diameter (mm)	425	425	425	425
Max shredding diameter (mm)	250	250	250	250
No. teeth type C/3+C/3/SS	42+2	46+2	-	-
type I+C/3/SS	58+2	66+2	-	-
No. hammers type FMM	-	-	32	36

Data refers to machine as standard. The technical data in this catalogue may be altered without prior notice.

MAIN OPTIONS

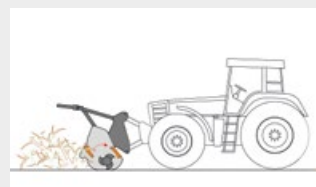

Frontal attachment

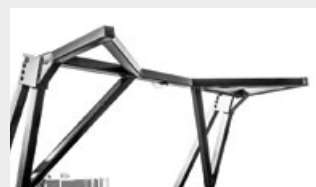

Mechanical or hydraulic guard frame guides and pushes material away from carrier



Extended 3 point linkage

ROTOR TYPE C



TOOTH C/3 (standard)



TOOTH C/3/HD (option)



BLADE BL (option - requires adaptor)



TOOTH K/3 (option)

ROTOR TYPE I



TOOTH I (option)



TOOTH C/3/SS (side scraper)



HAMMER FMM (standard)

FORESTRY MULCHERS

UML/S/DT

Forestry mulcher for PTO tractors with fixed tooth rotor.

The UML/S/DT is a professional forestry mulcher with a fixed rotor system and a mulching capacity up to 25 cm diameter. This unit is ideal for land clearing applications. The frame makes the mulcher more maneuverable when working on steep slopes and in extreme conditions.

This model features the interchangeable Spike counterblades, adjustable skeeds and inner anti-wear clades, as standard equipment. As an option, the UML/S/DT can mount mechanical or hydraulic guard frame with ripper guide pins.



130-190 hp



Ø 25 cm max

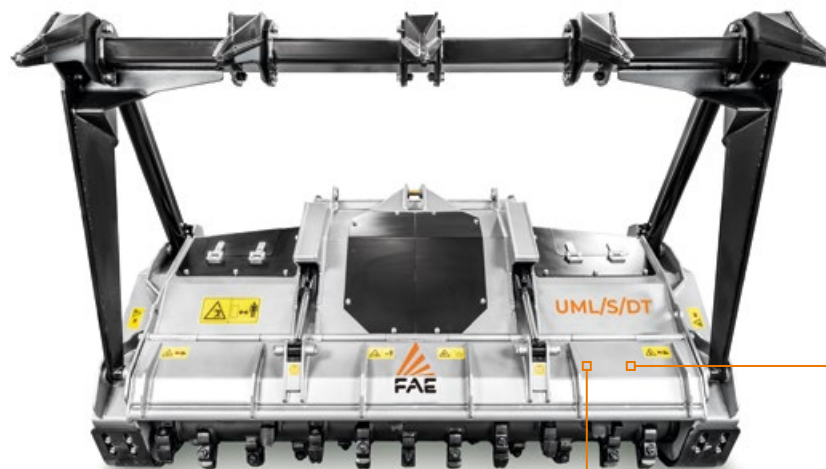

Interchangeable bolted on spike counter blade can adjust final product size while operating



Inner anti wear clad plates FCP absorbs wear while protecting the frame



Z style self ranging system of the PTO drive shaft/gearbox always keeps the correct operating angle between the PTO shaft and the power take-off (optional)

MAIN OPTIONS

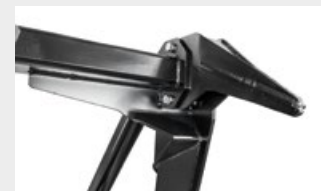

Extra ripper for push frame



Special skids to go underground



W style self aligning device between PTO drive shaft/gearbox allows the mulcher to work in several angles without damaging the PTO

STANDARD EQUIPMENT

Hydraulic rear hood	Transmission with belts
Inner anti wear clad plates FCP	Gearbox with freewheel
Enclosed machine body	PTO shaft with cam clutch
Centralized greasing hub	Bolted-on rotor shafts (in forged steel)
Hydraulic hoses integrated in the frame	Interchangeable bolted on spike counter-blade
Cylinder protection	Adjustable skids
Bolted on protection chains	Supporting service leg

OPTIONS

Frontal attachment (UML/S/DT 225)	W style self aligning device between PTO drive shaft/gearbox
Bolt-on chain's protection plates	Special skids to go underground
Multiple tooth options	Mechanical guard frame
Hydraulic top link	Hydraulic guard frame
Z style self ranging system of the PTO drive shaft/gearbox	Extra ripper for guard frame

MODEL	UML/S/DT 200	UML/S/DT 225
Tractor (hp)	130-190	130-190
PTO (rpm)	1000	1000
Working width (mm)	2067	2307
Total width (mm)	2430	2670
Weight (kg)	1690	1825
Rotor diameter (mm)	450	450
Max shredding diameter (mm)	250	250
No. teeth type C/3+C/3/SS	42+2	48+4
type I+C/3/SS	60+2	66+2

Data refers to machine as standard. The technical data in this catalogue may be altered without prior notice.

ROTOR TYPE C



TOOTH C/3 (standard)



TOOTH C/3/HD (option)



BLADE BL (option - requires adaptor)



TOOTH K/3 (option)

ROTOR TYPE I



TOOTH I (option)



TOOTH C/3/SS (side scraper)

FORESTRY MULCHERS

UMM/DT

Forestry mulcher for PTO tractors with fixed tooth rotor.

The UMM/DT is a professional forestry mulcher with a fixed rotor system and a mulching capacity up to 30 cm in diameter. This unit is ideal for heavy land clearing applications. The frame has been completely redesigned and it makes the mulcher more maneuverable when working on steep slopes and in extreme conditions.

This model features the new counterblade Spike PRO as standard equipment, and features the new hydrodynamic joints as an option. The UMM/DT also features interchangeable antiwear plates in Hardox® steel, new centralized greasing system and guide frame with Ripper guide pins.



160-240 hp



Ø 30 cm max

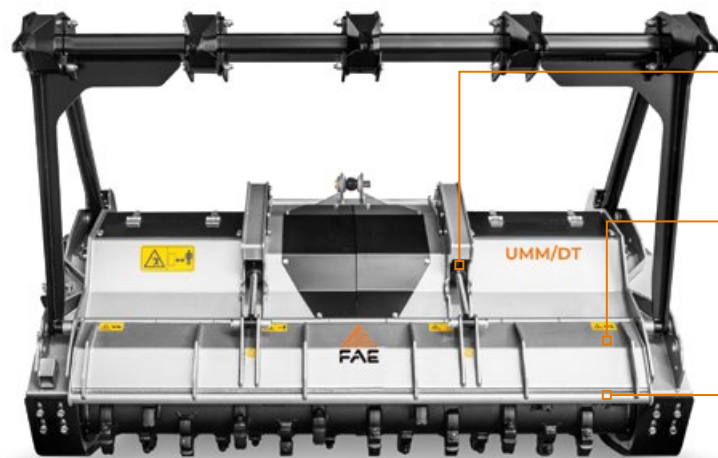

Cylinder protection
to prevent cylinder damage

Reinforced hydraulic hood
helps provide a finer product while being more durable

Forged and hardened interchangeable counter-blades
for the longest working life while providing a finer product



Z style self ranging system of the PTO drive shaft/gearbox
helps keep the correct operating angle between the PTO shaft and the power take-off

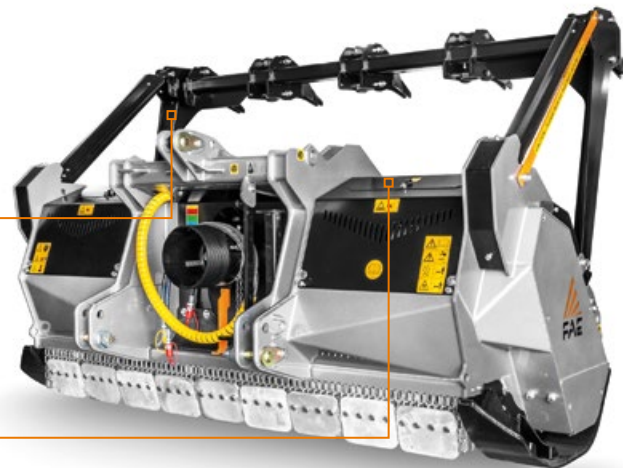

Centralized greasing hub
allows easy maintenance

MAIN OPTIONS



W style self aligning device between PTO drive shaft/gearbox
allows the mulcher to work in several angles without damaging the PTO



Standard hydraulic clutch transmission
protects the transmission at PTO engagement for smooth starting and improves machine performance

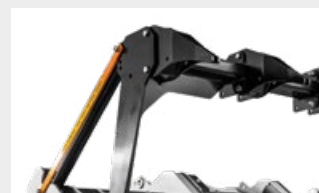

Mechanical/hydraulic push frame
guides and pushes material away from carrier



Additional ripper for push frame
helps with the positioning of standing material while mulching

STANDARD EQUIPMENT

Hydraulic rear hood	Gearbox with freewheel
Enclosed machine body	PTO shaft with cam clutch
Centralized greasing hub	Bolted-on rotor shafts (in forged steel)
Hydraulic hoses integrated in the frame	Hydraulic top link
Cylinder protection	Z style self ranging system of the PTO drive shaft/gearbox
Dual row protection chains	Interchangeable bolted on spike PRO counter-blade
Transmission with belts	Adjustable skids
Supporting service leg	

OPTIONS

Bolt-on chain's protection plates	Special skids to go underground
Hydraulic clutch transmission	Mechanical guard frame
Multiple tooth options	Hydraulic guard frame
W style self aligning device between PTO drive shaft/gearbox	Extra ripper for guard frame

MODEL	UMM/DT 200	UMM/DT 225	UMM/DT 250
Tractor (hp)	160-240	170-240	180-240
PTO (rpm)	1000	1000	1000
Working width (mm)	2070	2310	2550
Total width (mm)	2464	2704	2944
Weight (kg)	2230	2480	2550
Rotor diameter (mm)	500	500	500
Max shredding diameter (mm)	300	300	300
No. teeth type C/3+C/3/SS	42+2	46+2	52+2
type I+C/3/SS	68+2	78+2	86+2

Data refers to machine as standard. The technical data in this catalogue may be altered without prior notice.

ROTOR TYPE C



TOOTH C/3
(standard)



TOOTH C/3/HD
(option)



BLADE BL
(option - requires adaptor)



TOOTH K/3
(option)

ROTOR TYPE I



TOOTH I
(option)



TOOTH C/3/SS
(side scraper)

FORESTRY MULCHERS

UMH/S - UMH/S/HP

Forestry mulchers for PTO tractors with fixed tooth rotor.

The UMH is FAE's top of the line tractor mounted forestry mulcher. It is rated for trees up to 45 cm diameter and is designed to work with high horsepower tractors. The hydrodynamic joints and the Spike Pro counter-blades guarantee optimal performance and productivity. The ergonomics of the new, fully enclosed double layer "dustproof" frame is designed for maximum safety of the work and the operator. Finally, the large diameter of the rotor and the new Spike Pro counter-blades provide excellent homogenous shredding results. Backed by FAE's unparalleled engineering expertise, UMH/S/HP is built to last and delivers the maximum return on your investment.

The UMH is FAE's top of the line tractor mounted forestry mulcher. It is rated for trees up to 45 cm diameter and is designed to work with high horsepower tractors. The hydrodynamic joints and the Spike Pro counter-blades guarantee optimal performance and productivity. The ergonomics of the new, fully enclosed double layer "dustproof" frame is designed for maximum safety of the work and the operator. Finally, the large diameter of the rotor and the new Spike Pro counter-blades provide excellent homogenous shredding results. Backed by FAE's unparalleled engineering expertise, UMH/S/HP is built to last and delivers the maximum return on your investment.



240-500 hp



Ø 45 cm max



Spike Control Pro
and their distribution produce
a finer shredding result



Centralized greasing hub
for easier maintenance



**Adjustable extended
3 point hitch**
fits perfectly with
any kind of tractor

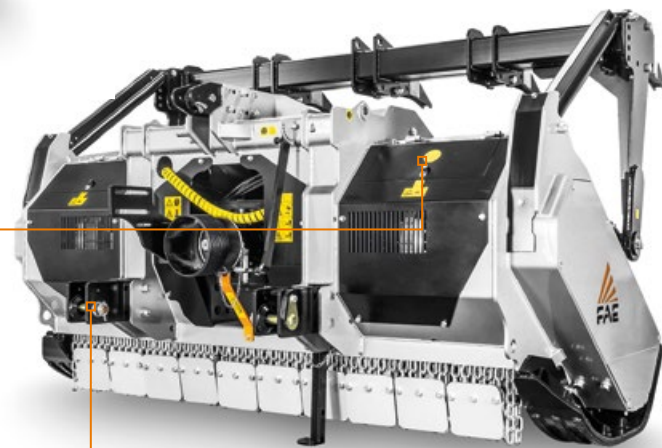

MAIN OPTIONS



W style self aligning device between PTO drive shaft/gearbox
allows the mulcher to work at several angles without damaging the PTO



Mechanical/hydraulic push frame
guides and pushes material away from carrier



Additional ripper for push frame
helps with the positioning of standing material while mulching



Standard hydraulic clutch transmission
protects the transmission at PTO engagement for smooth starting and improves machine performance

STANDARD EQUIPMENT

Hydraulic rear hood	Gearbox with oil cooling system (UMH/S/HP)
Inside lateral protection	PTO shaft
Adjustable extended 3 point linkage	Cam clutch on side PTO (UMH/S)
Enclosed machine body	Bolted-on rotor shafts (in forged steel)
Centralized greasing hub	Hydraulic top link
Hydraulic hoses integrated in the frame	Z style self ranging system of the PTO drive shaft/gearbox
Cylinder protection	Gearbox with freewheel
Bolted on protection chains	Interchangeable bolted on spike PRO counter-blade
Transmission with belts (UMH/S)	Adjustable skids
Poly-Chain® belts transmission (UMH/S/HP)	Supporting service leg
Hydraulic clutch transmission (UMH/S/HP)	

OPTIONS

Bolt-on chain's protection plates	Special skids to go underground
Hydraulic clutch transmission (UMH/S)	Mechanical guard frame
Multiple tooth options	Hydraulic guard frame
W style self aligning device between PTO drive shaft/gearbox	Extra ripper for guard frame

MODEL	UMH/S 225	UMH/S 250	UMH/S/HP 225	UMH/S/HP 250
Tractor (hp)	240-400	250-400	350-500	350-500
PTO (rpm)	1000	1000	1000	1000
Working width (mm)	2320	2560	2320	2560
Total width (mm)	2760	3000	2760	3000
Weight including rotor type C/3 (kg)	4200	4440	5100	5200
type A/3 (kg)	4510	4660	5400	5500
Rotor diameter (mm)	680	680	680	680
Max shredding diameter (mm)	400	400	450	450
No. teeth type A/3+MH	88+2	96+2	88+2	96+2
type C/3+C/3/SS	54+2	60+2	54+2	60+2

Data refers to machine as standard. The technical data in this catalogue may be altered without prior notice.

ROTOR TYPE A



TOOTH A/3
(standard)



TOOTH A/3/HD
(option)



TOOTH MH
(side scraper)

ROTOR TYPE C



TOOTH C/3
(standard)



TOOTH C/3/HD
(option)



TOOTH K/3
(option)



TOOTH C/3/SS
(side scraper)

FORESTRY MULCHERS

UMH/MEGA

Forestry mulcher for PTO tractors with fixed tooth rotor.

UMH/MEGA is a unique forestry mulcher. It is designed for the most powerful tractors available, and allows you to work large areas in a quick and effective way. The UMH/MEGA was built for operators seeking a

highly productive mulcher combined with an extremely efficient tiller. It can mulch trees up to 50 cm diameter and grind at a depth of 25 cm, all in one machine.

 350-500 hp

 Ø 50 cm max

 Depth 25 cm

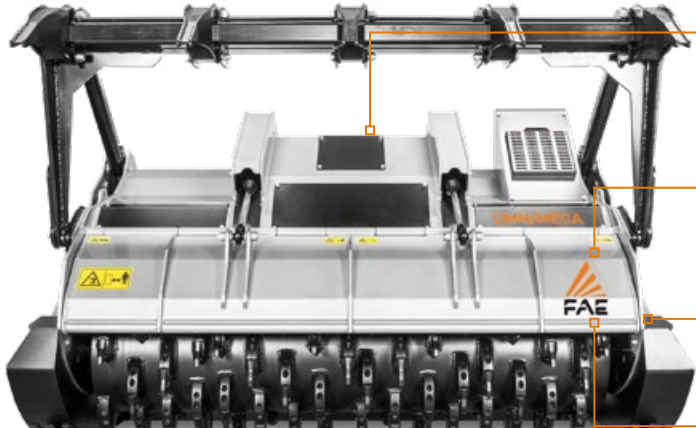



Z style self-ranging system for the PTO drive shaft/gearbox
helps keep the correct operating angle between the PTO shaft and the power take-off

Three rows of forged and hardened interchangeable counter-blades
for the longest working life while providing a finer product

Aggressive body design
the protruding rotor allows more material to process without dragging

Inner anti wear clad plates FCP
absorbs wear while protecting the frame

Standard hydraulic clutch transmission
protects the transmission at PTO engagement for smooth starting and improves machine performance



Adjustable extended 3 point hitch
fits perfectly with any type of tractor

Side transmission with belts in Poly-Chain® Carbon
for longer lasting performance

STANDARD EQUIPMENT

Hydraulic rear hood	Hydraulic clutch transmission
Inner anti wear clad plates FCP	Gearbox with freewheel
Adjustable extended 3 point linkage	Gearbox with oil cooling system
Enclosed machine body	PTO shaft
Centralized greasing hub	Bolted-on rotor shafts (in forged steel)
Hydraulic hoses integrated in the frame	Hydraulic top link
Cylinder protection	Z style self ranging system of the PTO drive shaft/gearbox
Inside lateral protection	Forged and hardened interchangeable counter-blades
Dual row protection chains	Third row of interchangeable forged and hardened counter-blades
Poly-Chain® belts transmission	

OPTIONS

Multiple tooth options	Mechanical guard frame
W style self aligning device between PTO drive shaft/gearbox	Hydraulic guard frame
Hydraulically adjustable skids	Extra ripper for push frame
Special skids to go underground	

MODEL	UMH/MEGA 225	UMH/MEGA 250
Tractor (hp)	350-500	350-500
PTO (rpm)	1000	1000
Working width (mm)	2320	2560
Total width (mm)	2820	3060
Weight (kg)	5970	6320
Rotor diameter (mm)	910	910
Max shredding diameter (mm)	500	500
Max working depth (mm)	250	250
No. teeth type A/3+MH	94+2	106+2

Data refers to machine as standard. The technical data in this catalogue may be altered without prior notice.

MAIN OPTIONS



Hydraulically adjustable skids
allow the rotor to penetrate deeply into the soil for grinding stumps and roots



W style self aligning device between PTO drive shaft/gearbox
allows the mulcher to work at several angles without damaging the PTO



Mechanical/hydraulic push frame
guides and pushes material away from carrier



Additional ripper for push frame
helps with the positioning of standing material while mulching

ROTOR TYPE A



TOOTH A/3
(standard)



TOOTH A/3/HD
(option)



TOOTH MH
(side scraper)

FORESTRY TILLERS

Forestry tillers are great for shredding and crushing stumps and deep roots underground on uncultivated land. Shredding even large-diameter stumps and uprooting leftover material deep in the soil, they clear land effectively. The quality of the materials and technology used make FAE forestry tillers unbeatably durable and reliable.



SSL SPEED

Forestry tiller for PTO tractors with fixed teeth rotor.



SSL

Forestry tiller for PTO tractors with fixed teeth rotor.



SSM - SSM/HP

Fixed tooth tiller for medium/high power tractors.



SSH - SSH/HP

Tiller for medium/high and extremely high power tractors.



FOR DEEP **WORK.**

MODEL	100 - 200 hp	200 - 300 hp	300 - 400 hp	400 - 500 hp
SSL SPEED	100 - 220 hp			
SSL	100 - 220 hp			
SSM - SSM/HP		150 - 300 hp		
SSH - SSH/HP		160 - 500 hp		

FORESTRY TILLERS

SSL SPEED

Forestry tiller for PTO tractors with fixed teeth rotor.

A Forestry Tiller designed to meet the needs of professionals who require both surface clearing and soil reclamation. This machine allows you to clean up crop residue and grind trees and stumps up to 30 cm diameter and 30 cm deep.

The optional push frame mounts to the support roller, while adjustable counter-blades are used to manually control the final product size.



100-220 hp



Ø 30 cm max



Depth 30 cm



Adjustable counter-blade for longer working life



Dual transmission with side gearbox increase power delivery to the rotor



STANDARD EQUIPMENT

Hydraulic rear hood	Friction clutches (SSL/DT SPEED)
Enclosed machine body	PTO shaft with cam clutch
Inside lateral protection	Bolted-on rotor shafts (in forged steel)
Protection chains	Welded steel counter-blades
Transmission with side gearbox	Adjustable counter-blade (forest)
Gearbox with freewheel	

OPTIONS

Multiple tooth options	Hydraulic guard frame
Hydraulic top link	Hydraulic support roller

MODEL	SSL SPEED 150	SSL SPEED 175	SSL/DT SPEED 200	SSL/DT SPEED 225	SSL/DT SPEED 250
Tractor (hp)	100-160	110-160	120-220	130-220	140-220
PTO (rpm)	1000	1000	1000	1000	1000
Working width (mm)	1600	1840	2080	2320	2560
Total width (mm)	1920	2160	2400	2640	2880
Weight (kg)	2000	2160	2600	2810	3030
Rotor diameter (mm)	600	600	600	600	600
Max shredding diameter (mm)	300	300	300	300	300
Max working depth (mm)	300	300	300	300	300
No. teeth type B/3+C/3/SS	44+4	50+4	58+4	66+4	74+4

Data refers to machine as standard. The technical data in this catalogue may be altered without prior notice.

MAIN OPTIONS



Hydraulic controlled roller helps with compaction and working uneven terrain



Hydraulic top link

ROTOR TYPE B



TOOTH B/3 (standard)



TOOTH B/3/HD (option)



TOOTH G/3 (option)



TOOTH G/3/HD (option)



TOOTH C/3/SS (side scraper)

FORESTRY TILLERS

SSL

Forestry tiller for PTO tractors with fixed teeth rotor.

This is the smallest model in FAE's line of Forestry Tillers. Thanks to its low weight and multiple working width options, the SSL fits a wide range of tractors. The transmission with side gearbox allows the rotor

to spin at a lower rpm than a traditional belt driven mulcher. This makes the transmission much more reliable, and ensures a deep, consistent grinding while also lowering tool wear.

 100-220 hp

 Ø 30 cm max

 Depth 30 cm



Reinforced hydraulic hood helps provide a finer product while being more durable



Dual transmission with side gearbox increase power delivery to the rotor



STANDARD EQUIPMENT

Hydraulic rear hood	Gearbox with freewheel
Enclosed machine body	Friction clutches (SSL/DT)
Inside lateral protection	PTO shaft with cam clutch
Protection chains	Bolted-on rotor shafts (in forged steel)
Transmission with side gearbox	Flat pressed welded steel counter-blades

OPTIONS

Multiple tooth options	Hydraulic support roller
Hydraulic top link	Two disc front plows

MODEL	SSL/ST 150	SSL/ST 175	SSL/DT 200	SSL/DT 225	SSL/DT 250
Tractor (hp)	100-160	110-160	120-220	130-220	140-220
PTO (rpm)	1000	1000	1000	1000	1000
Working width (mm)	1600	1840	2080	2320	2560
Total width (mm)	1920	2160	2400	2640	2880
Weight (kg)	2080	2260	2620	2810	2990
Rotor diameter (mm)	600	600	600	600	600
Max shredding diameter (mm)	300	300	300	300	300
Max working depth (mm)	300	300	300	300	300
No. teeth type B/3+C/3/SS	54+4	66+4	74+4	82+4	96+4

Data refers to machine as standard. The technical data in this catalogue may be altered without prior notice.

MAIN OPTIONS



Hydraulic controlled roller helps with compaction and working uneven terrain



Hydraulic top link

ROTOR TYPE B



TOOTH B/3
(standard)



TOOTH B/3/HD
(option)



TOOTH G/3
(option)



TOOTH G/3/HD
(option)



TOOTH C/3/SS
(side scraper)

FORESTRY TILLERS

SSM - SSM/HP

Fixed tooth tiller for medium/high power tractors.

The SSM has been designed and built to be used with medium to high-power tractors (150 to 300 hp). It clears land perfectly, shredding logs up to 50 cm in diameter at a max. depth of 40 cm. SSM also comes in an HP model for tractors up to 300 hp. Both models can be equipped with Standard or Heavy Duty teeth

to work in different soils and ensure the superb performance required to meet different needs. Available options include forestry counter blades for wood clearing, a rear roller, and an automatic universal joint alignment system.



150-300 hp

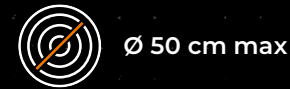

Ø 50 cm max



Depth 40 cm

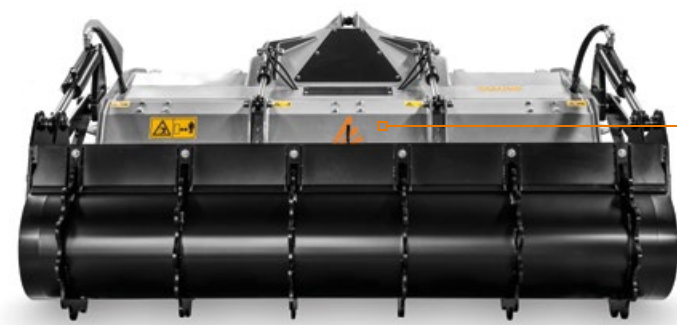

Adjustable Hardox® counter-blade

Z style self-ranging system for the PTO drive shaft/gearbox
helps keep the correct operating angle between the PTO shaft and the power take-off

Stronger transmission for tractors up to 300 hp power
(SSM/HP 200, 225 and 250)

Protection chains

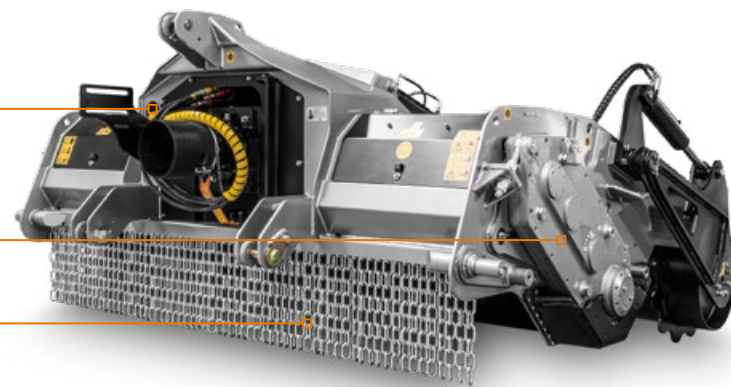

MAIN OPTIONS



W style self-aligning device between PTO drive shaft/gearbox
allows the mulcher to work in several angles without damaging the PTO



Adjustable counter-blade (forest)
for additional processing of wood material



Hydraulic controlled roller
helps with compaction and working uneven terrain

STANDARD EQUIPMENT

Hydraulic rear hood	PTO shaft with cam clutch
Enclosed machine body	Bolted-on rotor shafts (in forged steel)
Inside lateral protection	Hydraulic top link
Protection chains	Z style self-ranging system of the PTO drive shaft/gearbox
Transmission with side gearbox	Flat pressed welded steel counter-blades
Gearbox with freewheel	Adjustable Hardox® counter-blade
Friction clutches	Centralized greasing hub

OPTIONS

Bolted grid on rear hood	Adjustable counter-blade (forest)
Multiple tooth options	Dozing blade
W style self-aligning device between PTO drive shaft/gearbox	Hydraulic support roller

MODEL	SSM 200	SSM 225	SSM 250	SSM/HP 200	SSM/HP 225	SSM/HP 250
Tractor (hp)	150-250	170-250	190-250	150-300	170-300	190-300
PTO (rpm)	1000	1000	1000	1000	1000	1000
Working width (mm)	2080	2320	2560	2080	2320	2560
Total width (mm)	2410	2650	2890	2410	2650	2890
Weight (kg)	3090	3340	3590	3140	3390	3640
Rotor diameter (mm)	670	670	670	670	670	670
Max shredding diameter (mm)	500	500	500	500	500	500
Max working depth (mm)	400	400	400	400	400	400
No. teeth type A/3+MH	76+4	88+4	102+4	76+4	88+4	102+4

Data refers to machine as standard. The technical data in this catalogue may be altered without prior notice.

ROTOR TYPE A



TOOTH A/3
(standard)



TOOTH A/3/HD
(option)



TOOTH F/3
(option)



TOOTH MH
(side scraper)

FORESTRY TILLERS

SSH - SSH/HP

Tiller for medium/high and extremely high power tractors.

SSH and SSH/HP forestry tillers for 160 to 500 hp tractors ensure superior performance and reliability. The large rotor makes it possible to shred stumps up to 70 cm in diameter, and more teeth shred better than ever, even for roots up to 50 cm deep.

The combination of quality materials and technology - such as the counter blade and the interchangeable internal wear plates - provides unmatched productivity and reliability. The SSH/HP model also comes with a gearbox cooling system.



160-500 hp



Ø 70 cm max



Depth 50 cm

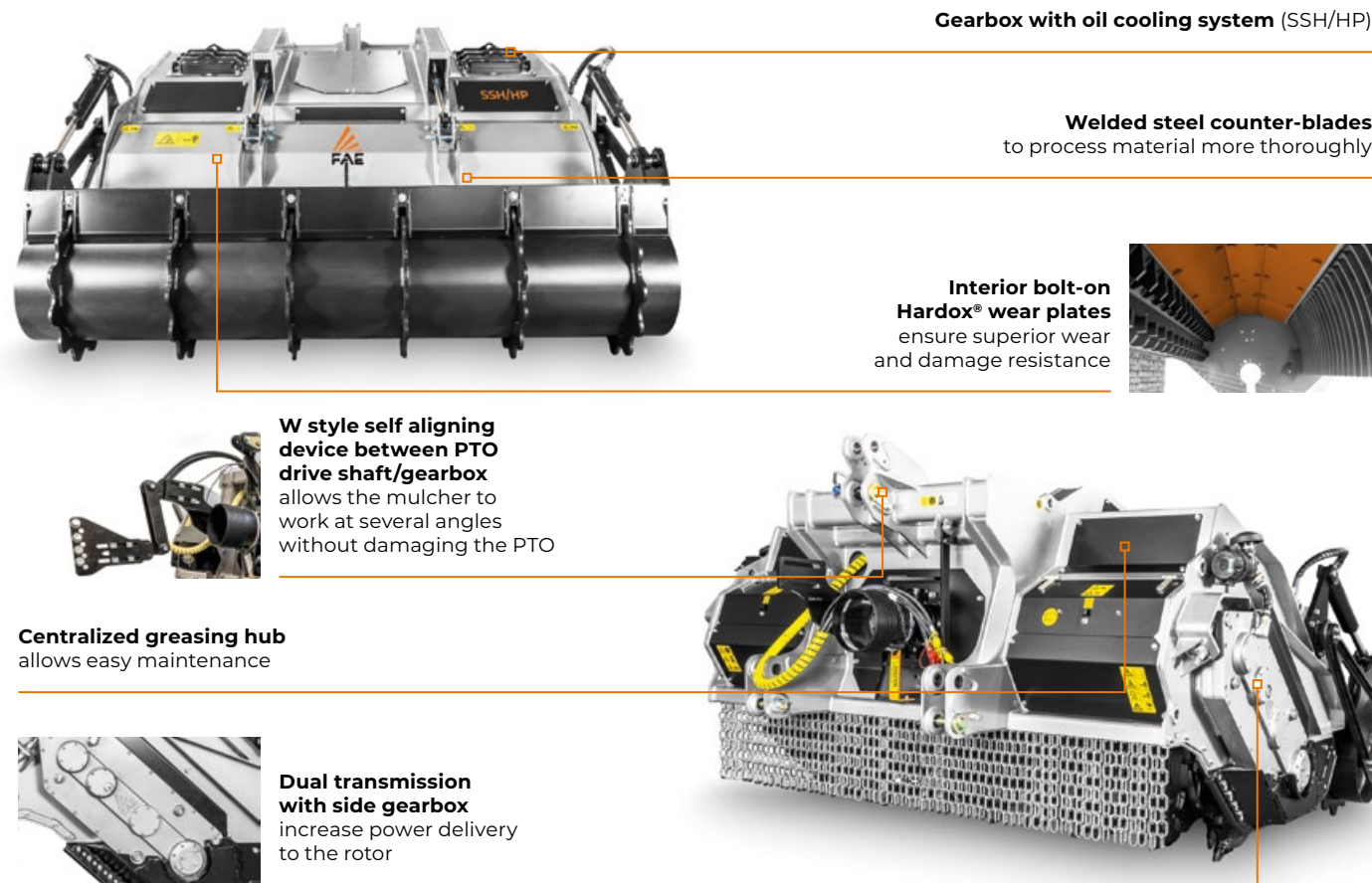

Gearbox with oil cooling system (SSH/HP)

Welded steel counter-blades
to process material more thoroughly

Interior bolt-on Hardox® wear plates
ensure superior wear and damage resistance

W style self aligning device between PTO drive shaft/gearbox
allows the mulcher to work at several angles without damaging the PTO

Centralized greasing hub
allows easy maintenance

Dual transmission with side gearbox
increase power delivery to the rotor

MAIN OPTIONS



Adjustable counter-blade (forest)
for additional processing of wood material



Hydraulic support roller or Wide hydraulic roller
produces fine-quality compacted soil faster

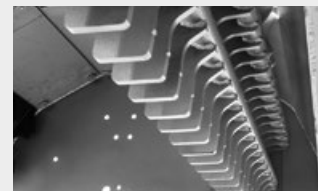

Independent Grid
for control of finer product; increased distance between the grid and the rear door allows a better material flow

STANDARD EQUIPMENT

Hydraulic rear hood	PTO shaft (SSH/HP)
Interchangeable inner antiwear plates in Hardox®	Friction clutches
Enclosed machine body	PTO shaft with cam clutch (SSH)
Inside lateral protection	Bolted-on rotor shafts (in forged steel)
Protection chains	Hydraulic top link
Transmission with side gearbox	Z style self ranging system of the PTO drive shaft/gearbox
Side gearbox with oil cooling system (SSH/HP)	Adjustable Hardox® counter-blade
Gearbox with freewheel	Special skids to go underground
Gearbox with oil cooling system (SSH/HP)	Centralized greasing hub

OPTIONS

Stronger transmission for tractors up to (SSH 200 - 225 - 250)	Skids extension (SSH - SSH/HP 200 - 225 - 250)
Multiple tooth options	Dozing blade
W style self aligning device between PTO drive shaft/gearbox	Hydraulic support roller
Adjustable counter-blade (forest)	Increased hydraulic roller

MODEL	SSH 150	SSH 175	SSH 200	SSH 225	SSH 250	SSH/HP 225	SSH/HP 250
Tractor (hp)	160-280	180-280	200-360 (400*)	200-360 (400*)	200-360 (400*)	360-500	360-500
PTO (rpm)	1000	1000	1000	1000	1000	1000	1000
Working width (mm)	1600	1840	2080	2320	2560	2320	2560
Total width (mm)	1980	2220	2472	2712	2952	2712	2952
Weight (kg)	3690	3920	4850	5200	5640	5310	5680
Rotor diameter (mm)	900	900	900	900	900	900	900
Max shredding diameter (mm)	700	700	700	700	700	700	700
Max working depth (mm)	500	500	500	500	500	500	500
No. teeth type A/3+MH	58+4	66+4	78+4	88+4	98+4	88+4	98+4

Data refers to machine as standard. The technical data in this catalogue may be altered without prior notice.

*Stronger trasmission.

ROTOR TYPE A



TOOTH A/3
(standard)



TOOTH A/3/HD
(option)



TOOTH F/3
(option)



TOOTH MH
(side scraper)

STUMP CUTTERS

Stump cutters are great for cutting and grinding stumps deep underground, shredding even large-diameter stumps and uprooting leftover material deep in the soil. The quality of the materials and technology used make FAE stump cutters unbeatably durable and reliable.



SCH

Stump cutter for tractors,
for individual stumps.



SCH/GT

Stump cutter for tractors,
for rows of stumps.



STUMP CUTTERS

STRAIGHT TO THE TARGET,
NO MATTER HOW DEEP.

MODEL	100 - 200 hp	200 - 300 hp	300 - 400 hp
SCH		160 - 280 hp	
SCH/GT		180 - 350 hp	

STUMP CUTTERS

SCH

Stump cutter for tractors, for individual stumps.

SCH is a stump cutter designed to remove individual stumps in wooded areas, parks and farmland cleared of tall trees. This head is perfect for 160 to 280 hp tractors and has a working depth of 50 cm. SCH has a hydraulic side shift system that lets the operator adjust to the working area without having to make additional maneuvers with the tractor.

It is extremely easy to use and shreds uniformly, even for extremely wide stumps. It is possible to mount either Standard or Heavy Duty teeth, ensuring superior performance in all sorts of terrain.



160-280 hp



Depth 50 cm



Transmission with belts



Hydraulic side shifting allows the stump cutter to move easily, quickly, and accurately while working close to plants and crops without damaging them

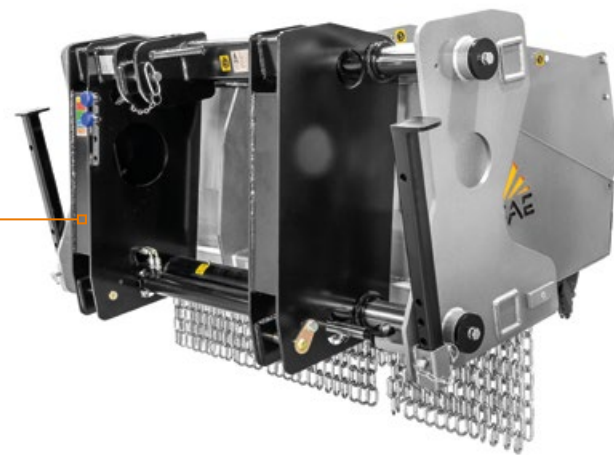

STANDARD EQUIPMENT

Hydraulic side shifting	PTO shaft with cam clutch
Enclosed machine body	Bolted-on rotor shafts (in forged steel)
Dual row protection chains	Supporting service leg
Transmission with belts	

OPTIONS

Multiple tooth options	Hydraulic top link
------------------------	--------------------

MODEL

SCH/SS/DT 55

Tractor (hp)	160-280
PTO (rpm)	1000
Working width (mm)	630
Total width (mm)	1800
Weight (kg)	2700
Rotor diameter (mm)	910
Max working depth (mm)	500
No. teeth type A/3+MH	34+4

Data refers to machine as standard. The technical data in this catalogue may be altered without prior notice.

MAIN OPTIONS



Hydraulic top link

ROTOR TYPE A



TOOTH A/3
(standard)



TOOTH A/3/HD
(option)



TOOTH F/3
(option)



TOOTH MH
(side scraper)

STUMP CUTTERS

SCH/GT

Stump cutter for tractors, for rows of stumps.

The SCH/GT model is a stump cutter designed for shredding rows of stumps, for example in poplar groves or eucalyptus fields. This head is perfect for 180-350 hp tractors and has a working depth of 60 cm. It also comes with internal Hardox® wear plates. Its dual clutch transmission provides superior performance and excellent power management.

SCH/GT models (except for the SCH/GT 75 model) have a hydraulic side shift system that lets the operator adjust to the working area without having to make additional maneuvers with the tractor. It is extremely easy to use and shreds stumps uniformly.



180-350 hp



Depth 60 cm



Dual transmission with side gearbox increase power delivery to the rotor



Hydraulic side shifting allows the stump cutter to move easily, quickly, and accurately while working close to plants and crops without damaging them



STANDARD EQUIPMENT

Hydraulic side shifting (excluding SCH/GT/DT 75)	Gearbox with freewheel
Enclosed machine body	PTO shaft with cam clutch
Inside lateral protection	Bolted-on rotor shafts (in forged steel)
Protection chains	Welded steel counter-blades
Transmission with side gearbox	Supporting service leg

OPTIONS

Multiple tooth options	Hydraulic top link
------------------------	--------------------

MODEL	SCH/GT/DT 65	SCH/GT/DT 75
Tractor (hp)	180-300	200-350
PTO (rpm)	1000	1000
Working width (mm)	730	810
Total width (mm)	1800	1980
Weight (kg)	2900	3690
Rotor diameter (mm)	900	1100
Max working depth (mm)	500	600
No. teeth type A/3+MH	28+4	34+4

Data refers to machine as standard. The technical data in this catalogue may be altered without prior notice.

MAIN OPTIONS



Hydraulic top link

ROTOR TYPE A



TOOTH A/3
(standard)



TOOTH A/3/HD
(option)



TOOTH F/3
(option)



TOOTH MH
(side scraper)

STONE CRUSHERS

Designed for reclamation of uncultivated soil with stones.
Our stone crushers allow you to work in narrow spaces more easily while also maintaining an accurate lane.
Hardox® steel lines the crushing chamber, making our machines heavy duty and resistant to abrasion.
This makes your investment last longer and maintain production over its working life.



STCL
Stone crusher for PTO tractors with fixed teeth rotor.



STC
Stone crusher for PTO tractors with fixed teeth rotor.



STCH
Stone crusher for PTO tractors with fixed teeth rotor.



RSL
Stone crusher for PTO tractors with fixed teeth rotor.



RSM - RSM/HP
The stone crusher for difficult tasks.



RSH/HP
FAE's top-of-the-line stone crushers.



THE POWER YOU'RE LOOKING FOR.

MODEL	0 - 100 hp	100 - 200 hp	200 - 300 hp	300 - 400 hp	400 - 500 hp
STCL		70 - 150 hp			
STC		80 - 220 hp			
STCH				280 - 400 hp	
RSL		80 - 190 hp			
RSM - RSM/HP			200 - 360 hp		
RSH/HP					360 - 500 hp

STONE CRUSHERS

STCL

Stone crusher for PTO tractors with fixed teeth rotor.

The STCL is the smallest stone crusher FAE makes. It is extremely versatile thanks to its small dimension and lower weight. This makes it suitable for use in orchards and vineyards where stones can emerge due to soil erosion. An adjustable internal counter-blade allows you to obtain the desired final material size.

The hydraulically controlled rear door also helps in determining final product size. This attachment also has a specially mounted gearbox so while it sits in a low position, the PTO shaft still sits at an optimal angle.



70-150 hp



Ø 15 cm max (stones)



Depth 15 cm



Enclosed machine body
protects internal components

Adjustable Hardox® counter-blade
effectively control the final product size



Adjustable extended 3 point hitch
fits perfectly with any kind of tractor



Penetration skids
help the machine to better penetrate the soil

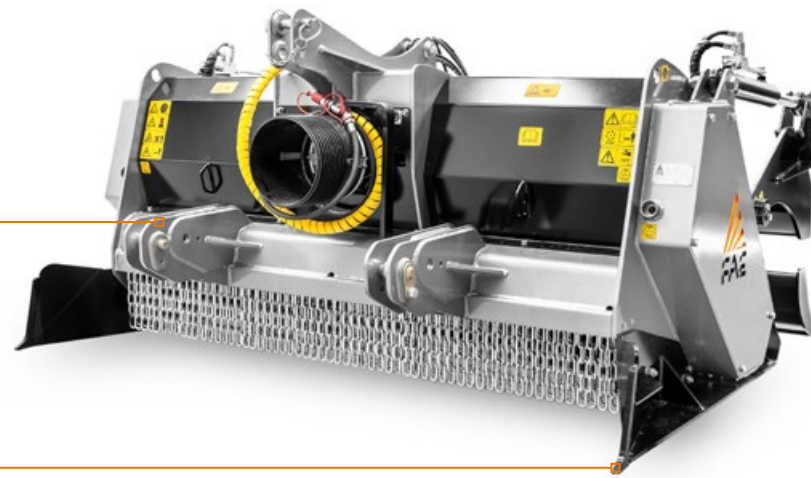

STANDARD EQUIPMENT

Hydraulic rear hood	Gearbox with freewheel
Inner anti wear clad plates FCP	Possibility to choose Transmission 540 / 1000 rpm (STCL/ST)
Adjustable extended 3 point linkage (STCL/ST)	PTO shaft with cam clutch
Enclosed machine body	Bolted-on rotor shafts (in forged steel)
Inside lateral protection	Flat pressed welded steel counter-blades
Dual row protection chains	Adjustable Hardox® counter-blade
Poly-Chain® belts transmission	Penetration skids

OPTIONS

Extended 3 point linkage (STCL/ST)	Grader blade (road kit)
Hydraulic top link	Dozing blades

MODEL	STCL/ST 100	STCL/ST 125	STCL/ST 150	STCL/ST 175	STCL/DT 175	STCL/DT 200
Tractor (hp)	70-120*	80-120*	90-120*	100-120*	100-150	120-150
PTO (rpm)	540-1000	540-1000	540-1000	540-1000	1000	1000
Working width (mm)	1110	1350	1590	1830	1830	2070
Total width (mm)	1414	1654	1894	2134	2134	2374
Weight (kg)	1230	1280	1440	1570	1600	1750
Rotor diameter (mm)	450	450	450	450	450	450
Max shredding diameter (mm)	150	150	150	150	150	150
Max working depth (mm)	150	150	150	150	150	150
No. teeth type STCL/3 + C/3/SS	22+4	26+4	32+4	38+4	38+4	42+4

Data refers to machine as standard. The technical data in this catalogue may be altered without prior notice.
*For 540 rpm tractors, max. power 100 hp.

MAIN OPTIONS

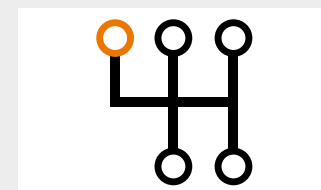

Possibility to choose transmission 540 / 1000 rpm (STCL 125)



Grader blade (road kit)
for grading and compaction



Dozing blade
to level the crushed material



TOOTH STCL/3
(standard)



TOOTH C/3/SS
(side scraper)

STONE CRUSHERS

STC

Stone crusher for PTO tractors with fixed teeth rotor.

The STC was designed and built to meet the needs of professionals requiring stone crushing up to 30 cm diameter and working in the ground up to 20 cm deep. With the exception of the STC 125, each STC model comes with a dual transmission to ensure even power distribution across the rotor.

Hardox® steel is used to line the crushing chamber along with the skids and ploughshare. This extends the life span of the STC and makes it a better investment for growing businesses.

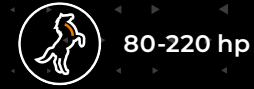

80-220 hp

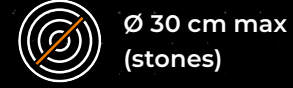

Ø 30 cm max (stones)



Depth 20 cm



Adjustable Hardox® counter-blade effectively control the final product size

Dual/single belt transmission



Skids with Hardox® skid plates and penetration points help the machine better penetrate the ground

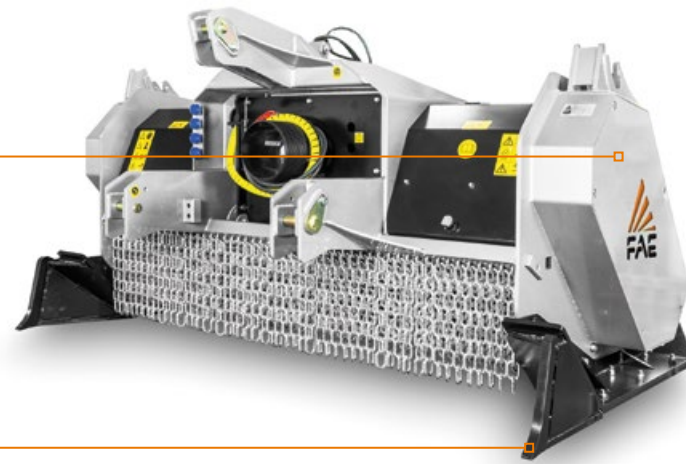

STANDARD EQUIPMENT

Hydraulic rear hood	PTO shaft with cam clutch
Enclosed machine body	Bolted-on rotor shafts (in forged steel)
Inside lateral protection	Flat pressed welded steel counter-blades
Dual row protection chains	Adjustable Hardox® counter-blade
Poly-V belts transmission	Adjustable skids
Gearbox with freewheel	Penetration skids
Possibility to choose Transmission 540 / 1000 rpm (STC/ST)	

OPTIONS

Multiple tooth options	Dozing blade
Hydraulic top link	Grader blade (road kit) (STC/DT)

MODEL	STC/ST 125	STC/DT 150	STC/DT 175	STC/DT 200
Tractor (hp)	80-110	100-220	120-220	130-220
PTO (rpm)	540-1000	1000	1000	1000
Working width (mm)	1340	1580	1820	2060
Total width (mm)	1760	2010	2250	2490
Weight (kg)	1850	2450	2690	2830
Rotor diameter (mm)	550	550	550	550
Max shredding diameter (mm)	300	300	300	300
Max working depth (mm)	200	200	200	200
No. teeth type STC/3+STC/3/HD	26+4	32+4	38+4	42+4

Data refers to machine as standard. The technical data in this catalogue may be altered without prior notice.

MAIN OPTIONS

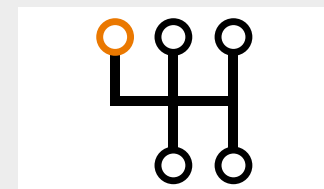

Possibility to choose transmission 540 / 1000 rpm



Grader blade (road kit) for grading and compaction



Dozing blade to level the crushed material



TOOTH STC/3 (standard)



TOOTH STC/3/HD (option)



TOOTH STC/3/FP (option)



TOOTH STC/3/HD (side scraper)

STONE CRUSHERS

STCH

Stone crusher for PTO tractors with fixed teeth rotor.

FAE renews the existing STCH range, adapting to the most powerful tractors (from 280 to 400 hp), with a maximum operating depth of 25 cm and the ability to crush stones up to 50 cm in diameter. Among the main technical innovations there is the hydraulic counter blade that can be adjusted directly from the tractor's cab, the oversized door and interchangeable

internal Hardox® protections. It is also equipped with a new side-scraper system to limit side wear, adjustable skids, as well as interchangeable protection chains. The three models available (with working widths of 200, 225 and 250 cm) make it perfect for different jobs, particularly to treat soils with large quantities of moving stones.



280-400 hp

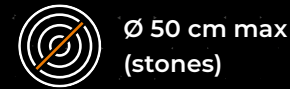

Ø 50 cm max (stones)



Depth 25 cm



Completely closed/dust-resistant machine body to protect the machine's transmission and components



Hydraulic rear hood for an optimal material sizing and control



Skids with interchangeable Hardox® shoes and ploughshares allows an easy maintenance & an improved machine penetration into the soil



Hydraulic counter-blade allows to check the size of the shredded material directly from the tractor cab

Oversized material inlet allows also to surface stones to enter the crushing chamber



Interchangeable internal Hardox® wear plates for use in extreme conditions and for easier maintenance

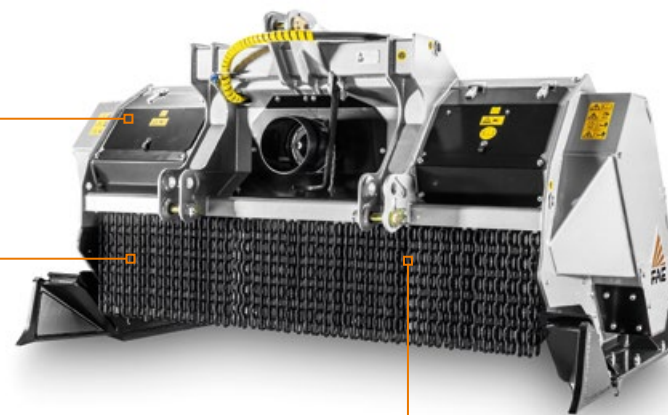

MAIN OPTIONS



Grader blade (road kit) for grading and compaction



Hydraulic top link for an optimal working depth control

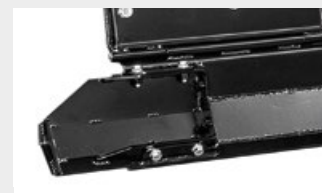

Dozing blade to level the crushed material



Dozing blade with springs system to level and compact the crushed material, creating a uniform base

STANDARD EQUIPMENT

Hydraulic rear hood	Gearbox with freewheel
Interchangeable inner antiwear plates in Hardox®	PTO shaft
Enclosed machine body	Cam clutch on side PTO
Centralized greasing hub	Bolted-on rotor shafts (in forged steel)
Inside lateral protection	Adjustable Hardox® counter-blade
Dual row protection chains	Adjustable skids
Transmission with belts	Penetration skids
Flat pressed welded steel counter-blades	

OPTIONS

Multiple tooth options	Grader blade (road kit)
Hydraulic top link	Dozing blades with spring system
Dozing blade	

MODEL	STCH 200	STCH 225	STCH 250
Tractor (hp)	280-400	280-400	280-400
PTO (rpm)	1000	1000	1000
Working width (mm)	2080	2320	2560
Total width (mm)	2566	2806	3046
Weight (kg)	4850	5050	5250
Rotor diameter (mm)	700	700	700
Max shredding diameter (mm)	500	500	500
Max working depth (mm)	250	250	250
No. teeth type STC/3+STC/3/HD+STC/FP	50+4+4	56+4+4	62+4+4

Data refers to machine as standard. The technical data in this catalogue may be altered without prior notice.



TOOTH STC/3 (standard)



TOOTH STC/3/HD (option)



TOOTH STC/3/FP (option)



TOOTH STC/3/HD (side scraper)



TOOTH STC/FP (side scraper)

STONE CRUSHERS

RSL

Stone crusher for PTO tractors with fixed teeth rotor.

The RSL is a multifunction head that enables crushing of stones and milling of slabs of rock, to a depth of 28 cm. The compact size, low weight and minimum operating width of 100 cm make it perfect in limited spaces. The gear transmission enables operation with

constantly optimal levels of torque and power. The dedicated teeth guarantee optimal results in the presence of stones and slabs of rock. The crushing chamber is protected by Hardox coatings to offer maximum wear resistance even in the most demanding conditions.



80-190 hp

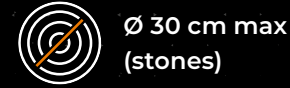

Ø 30 cm max (stones)



Depth 28 cm

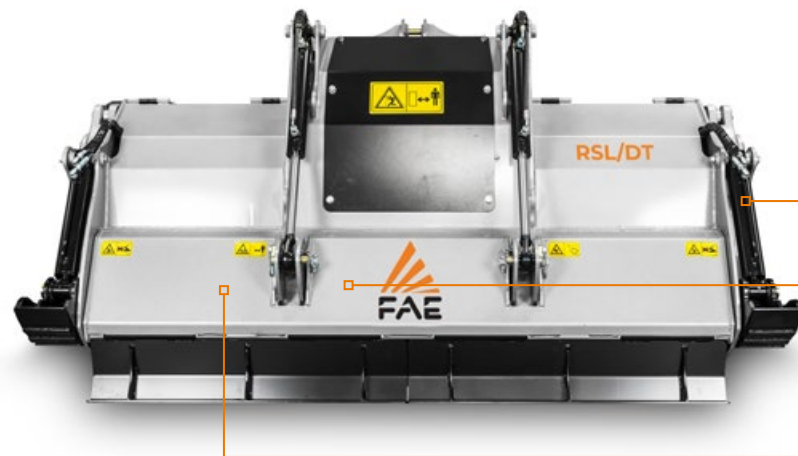

Side wear plates on the inner sides of the frame highly resistant to wear and tear, equalling less down time due to replacement



Rear access panel

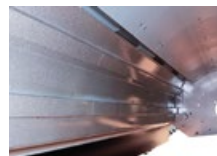

Hardox® Counter-blades (welded)



Rear grid
the grid on the rear door helps define the size of the output materials.

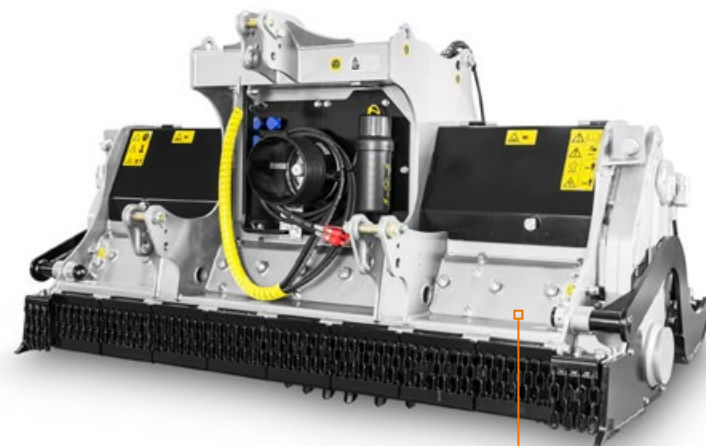

Hardox® steel - Wear plates
these allow the machine to resist wear and tear and can be easily replaced as needed

MAIN OPTIONS



Hydraulic top link



Bolt-on chain's protection plates



Multiple tooth options



The **Water Spray System** (Basic & High Flow) cools the teeth to help them last longer

STANDARD EQUIPMENT

Hydraulic rear hood	Gearbox with freewheel
Interchangeable inner antiwear plates in Hardox®	Friction clutches (RSL/DT)
Enclosed machine body	PTO shaft with cam clutch
Bolted grid on rear hood	Bolted-on rotor shafts (in forged steel)
Inside lateral protection	Flat pressed welded steel counter-blades
Protection chains	Hydraulically adjustable skirts
Transmission with side gearbox (RSL/DT)	Dozing blades

OPTIONS

Bolt-on chain's protection plates	Water spray system WSS Basic
Multiple tooth options	Water spray system WSS High Flow (RSL/DT)
Hydraulic top link	Extended 3 point linkage (RSL/ST)

MODEL	RSL/ST 100	RSL/ST 125	RSL/ST 150	RSL/DT 175	RSL/DT 200	RSL/DT 225
Tractor (hp)	80-120	90-120	100-120	120-190	130-190	140-190
PTO (rpm)	540	540	540	1000	1000	1000
Working width (mm)	1000	1240	1480	1720	1960	2200
Total width (mm)	1410	1650	1890	2130	2370	2610
Weight (Kg)	1600	1800	1960	2350	2500	2650
Max shredding diameter (mm)	300	300	300	300	300	300
Working depth (mm) (Max. 1-Max. 2)	150-280	150-280	150-280	150-280	150-280	150-280
ROTOR G/3						
No. teeth type G/3+STC/3/FP	28+6	36+6	42+6	50+6	60+6	70+6
Rotor diameter (mm)	595	595	595	595	595	595
Working depth (mm) (Max. 1-Max. 2)	160-280	160-280	160-280	160-280	160-280	160-280
ROTOR R						
No. picks type R/65+R/65/HD	58+16	74 +16	98+16	122+16	138+16	154+16
Rotor diameter (mm)	612	612	612	612	612	612

Max. 1: with rotor only **Max. 2:** maximum depth (maximum working depth depending on ground conditions).
This information refers to the machine equipped as standard. The technical data in this catalogue may be altered without prior notice.

ROTOR TYPE G



TOOTH G/3 (standard)



TOOTH G/3/HD (option)



ADAPTOR G/3 WITH PICK R/44 (option)

ROTOR TYPE R



PICK R/65 (standard)



PICK R/65/HD (option)



ADAPTOR R/65 WITH PICK R/44 (option)



TOOTH STC/3/FP (side scraper)



PICK R/65/HD (side scraper)

STONE CRUSHERS

RSM - RSM/HP

The stone crusher for difficult tasks.

RSM - RSM/HP models are designed to crush slabs of rock and stones up to 50 cm in diameter and 40 cm deep. They work with 200-360 hp tractors and have a working width of 200-230 cm. FAE's RSM line is made for difficult farmland clearing work in places where large rocks and stones need to be cleared to prepare the field for agricultural use.

Its wide opening guides large material towards the rotor and helps maintain consistently high performance when working the soil. An adjustable counterblade makes it possible to crush material to the desired fineness.



200-360 hp



Ø 50 cm max (stones)



Depth 40 cm



Structural frame in steel
maximum strength and durability
in heavy duty operations

**Interchangeable
Hardox® anti wear plates**
quick and easy maintenance



**Oil-cooling system
for side gears**
greater efficiency and lifespan
(optional for RSM)

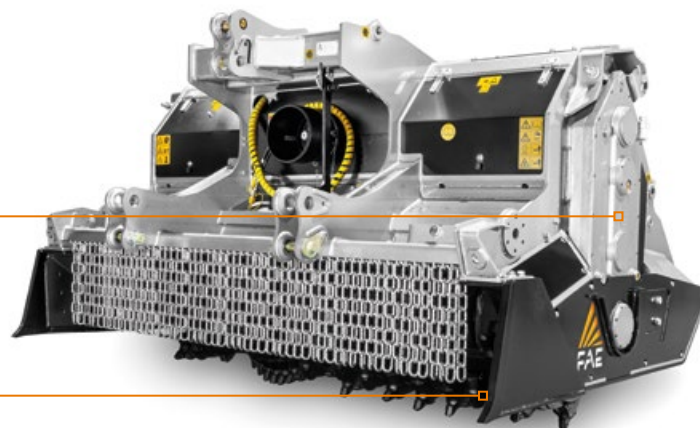

Wide opening
to efficiently process more material

MAIN OPTIONS



Rear hood grill
allows larger material to be held back and crushed again for optimum results



Adjustable steel dosing blade
perfect distribution of the crushed material



Hydraulic top link
precise control over operations



Steel dosing blades with spring system
excellent even distribution of material and precompaction

STANDARD EQUIPMENT

Hydraulic rear hood	Friction clutches
Interchangeable inner antiwear plates in Hardox®	PTO shaft with cam clutch (RSM)
Enclosed machine body	PTO shaft (RSM/HP)
Inside lateral protection	Bolted-on rotor shafts (in forged steel)
Protection chains	Adjustable Hardox® counter-blade
Transmission with side gearbox	Penetration skids
Gearbox with freewheel	Side gearboxes with oil cooling system (RSM/HP)

OPTIONS

Bolted grid on rear hood	Dozing blade
Multiple tooth options	Dozing blades with spring system
Hydraulic top link	Side gearbox with oil cooling system (RSM)

MODEL	RSM 200	RSM 225	RSM/HP 200	RSM/HP 225
Tractor (hp)	200-300	220-300	300-360	300-360
PTO (rpm)	1000	1000	1000	1000
Working width (mm)	2080	2320	2080	2320
Total width (mm)	2490	2730	2490	2730
Weight (kg)	5060	5490	5060	5490
G/3 rotor diameter (mm)	940	940	940	940
R rotor diameter (mm)	915	915	915	915
Max shredding diameter (mm)	500	500	500	500
Max working depth (mm)	400	400	400	400
No. teeth type G/3+STC/3/FP+STC/FP	94+4+4	106+4+4	94+4+4	106+4+4
type R/65+R/65/HD+STC/3/FP+STC/FP	126+20+4+4	144+20+4+4	126+20+4+4	144+20+4+4

Data refers to machine as standard. The technical data in this catalogue may be altered without prior notice.

ROTOR TYPE G



TOOTH G/3
(standard)



TOOTH G/3/HD
(option)

ROTOR TYPE R



PICK R/65
(option)



PICK R/65/HD
(option)



TOOTH STC/3/FP
(side scraper)



TOOTH STC/FP
(side scraper)

STONE CRUSHERS

RSH/HP

FAE's top-of-the-line stone crushers.

RSH/HP is FAE's most advanced stone crusher. It is suited for crushing slabs of rock and stones up to 50 cm in diameter and 50 cm deep. It works with 360-500 hp tractors and has a working width of 210-260 cm. RSH/HP is made for difficult farmland clearing work in places where large rocks and stones need to be cleared to prepare the field for agricultural use.

Its wide opening guides large material towards the rotor and, in combination with the adjustable counterblade, helps maintain consistently high performance when working the soil.



360-500 hp



Ø 50 cm max (stones)



Depth 50 cm



Structural frame in steel
maximum strength and durability
in heavy duty operations

Interchangeable Hardox® anti wear plates
quick and easy maintenance



Side reduction gears and central gearbox with oilcooling system
maximum productivity and efficiency
maintained in all working conditions

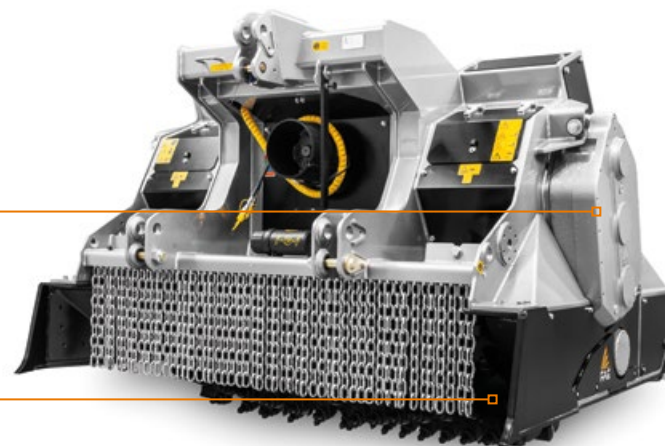

Wide opening
to efficiently process more material

MAIN OPTIONS



Rear hood grill
allows larger material to be held back and crushed again for optimum results



Adjustable steel dosing blade
perfect distribution of the crushed material



Hydraulic top link
precise control over operations

STANDARD EQUIPMENT

Hydraulic rear hood	Gearbox with freewheel
Interchangeable inner antiwear plates in Hardox®	Gearbox with oil cooling system
Enclosed machine body	PTO shaft
Inside lateral protection	Friction clutches
Protection chains	Bolted-on rotor shafts (in forged steel)
Transmission with side gearbox	Adjustable Hardox® counter-blade
Side gearbox with oil cooling system	Penetration skids

OPTIONS

Bolted grid on rear hood	Hydraulic top link
Multiple tooth options	Dozing blade

MODEL	RSH/HP 200	RSH/HP 225	RSH/HP 250
Tractor (hp)	360-500	360-500	360-500
PTO (rpm)	1000	1000	1000
Working width (mm)	2107	2347	2587
Total width (mm)	2670	2910	3150
Weight (kg)	7050	7450	7850
Max shredding diameter (mm)	500	500	500
Max working depth (mm)	500	500	500
ROTOR			
Rotor diameter (mm)	1115	1115	1115
G/3			
No. teeth type G/3	104	116	132
	type STC/3/FP+STC/FP	4+4	4+4
ROTOR			
Rotor diameter (mm)	1065	1065	1065
R65			
No. teeth/picks type R/65+R/65/HD	138+24	160+24	180+24
	type STC/3/FP+STC/FP	6+6	6+6

Data refers to machine as standard. The technical data in this catalogue may be altered without prior notice.

ROTOR TYPE G



TOOTH G/3
(standard)



TOOTH G/3/HD
(option)

ROTOR TYPE R



PICK R/65
(option)



PICK R/65/HD
(option)



TOOTH STC/3/FP
(side scraper)



TOOTH STC/FP
(side scraper)

MULTITASKS

FAE multitask units are designed for a multitude of applications and terrains. These highly versatile machines combine the features and efficiency of our stone crushers and tillers with the mulching power of our forestry mulchers. With multiple sizes of machines to choose from, FAE offers the most comprehensive selection of heavy duty attachments to fit your land reclaiming needs.



SFM

Stone crusher, forestry tiller and mulcher for PTO tractors with fixed tooth rotor.

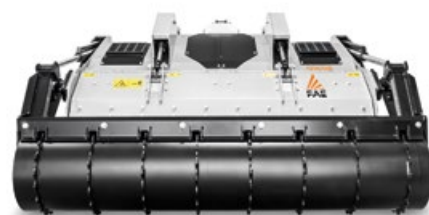

SFH - SFH/HP

Stone crusher, forestry tiller and mulcher for PTO tractors with fixed teeth rotor.



MULTITASKS

THREE GOALS WITH EQUAL EFFICIENCY.

MODEL	100 - 200 hp	200 - 300 hp	300 - 400 hp	400 - 500 hp
SFM		160 - 300 hp		
SFH - SFH/HP			300 - 500 hp	

Original FAE tools

UNMATCHED PERFORMANCE



TOOTH A/3



TOOTH A/3/HD



TOOTH F/3



TOOTH B/3



TOOTH B/3/HD



TOOTH G/3



TOOTH G/3/HD



TOOTH C/3



TOOTH C/3/HD



TOOTH STCL/3



TOOTH I



TOOTH K/3



TOOTH STC/FP



TOOTH MH (L)



TOOTH MH (R)



TOOTH C/3/SS (L)



TOOTH C/3/SS (R)



TOOTH C/3/MINI



TOOTH STC/3



TOOTH STC/3/HD



TOOTH STC/3/FP



BLADE BL



BLADE BL/MINI



PICK R/65



PICK R/65/HD



HAMMER FMM

The technical data in this catalog may be altered without prior notice.
The information and images in this document are not binding.
The weight is approximate and refers to machine without options.
The data in this catalog must be confirmed by the sales department.
Photographs may include accessories and equipment not supplied as standard. FAE GROUP S.p.A. reserves the right to make changes at any time, without prior warning.



